

# Heizohack®

ENERGY IN BALANCE WITH NATURE



**HM 4 – HM 6-300**



**HM 6-300 VM**



**HM 5 – HM 8-400**



**HM 8-400 K**



**HM 10-500 K**



**HM 14-800 K**



**HM 14-800 KT**



**HM 14-800 KL**

An on-board hydraulic system is standard equipment on our chippers, this guarantees a reliable in-feed of the chip material done by a speed reduction gear.

**Heizohack**<sup>®</sup>

**HM 4-300**

**HM 6-300**

max. trunk diameter  
30 cm = approx. 12 inch



The small version of our mobile HEIZOHACK disk-drum chippers.

	A	B	C	D	E	F	kg
HM 4-300	3213	370	3419	2265	2965	2422	1600
HM 6-300	3382	539	3419	2265	2965	2422	1800

A in-feed height of 30 cm makes it possible to cut bushes, branches, pales, saw mill waste etc. and even entire trunks in high-grade wood chips.

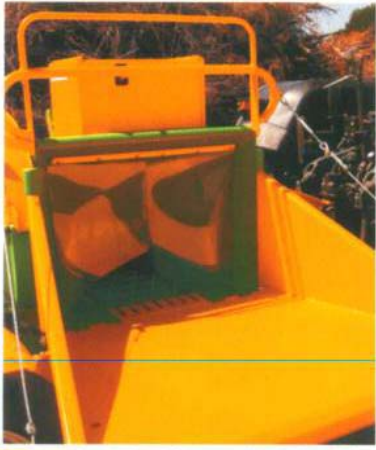
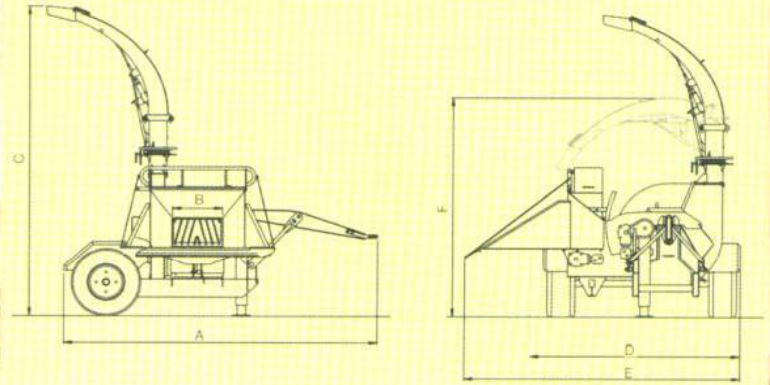

The HEIZOHACK in-feed controller adjusts the in-feed speed in relation with the performance of the tractor drive.

An integrated operation hour counter stores the operation hours per day and also in total. A short-term reverse of the trunk to discharge the drums is possible.

A volumeter, installed in the Hydro-control block regulates the general in-feed speed infinitely variable.

# Heizohack<sup>®</sup>

## HM 6-300 VM

max. trunk diameter 30 cm = approx. 12 inch



air-cooled  
**Hatz-Diesel**  
engine with  
**70 hp/51 kW**

Mounted on a trailer-chassis and towed by an off-road car or a small lorry, the chipper can be brought very fast to the place of use (max. speed 80 km/h). A turntable, fixed between chipper and chassis, makes it possible to turn the in-feed table in the direction of the chipping material.



	A	B	C	D	E	F	kg
HM 6-300-Hatz	4520	539	3681	2054	4959	2782	3100

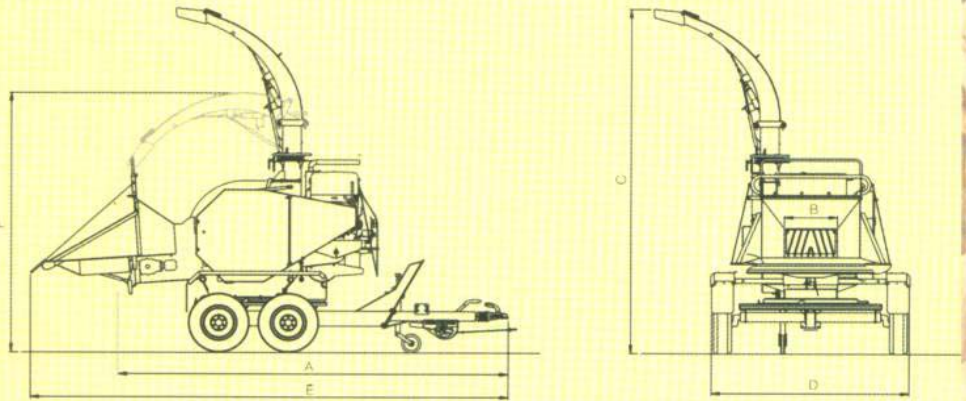

The performance of this motor driven chipper is unique. A disk-drum chipper with a reliable in-feed of trunks up to a diameter of 30 cm, done by a steel conveyer and a roller, and an ejection of high-grade wood chips.



# Heizohack<sup>®</sup>

**HM 5-400**

**HM 6-400**

**HM 8-400**

max. trunk diameter  
40 cm = approx. 16 inch

This hand-charged machine type has proven its reliability and toughness a hundred times during daily use.

The big sized ejector blower guarantees a proper ejection of the wood chips and a powerful pull. Exchangeable sieves provide fine wood chips in constant size and best quality.

	A	B	C	D	E	F	kg
HM 5-400	3343	451	3502	2265	3105	2588	3000
HM 6-400	3427	539	3502	2265	3105	2588	3200
HM 8-400	3596	708	3502	2265	3105	2588	3400

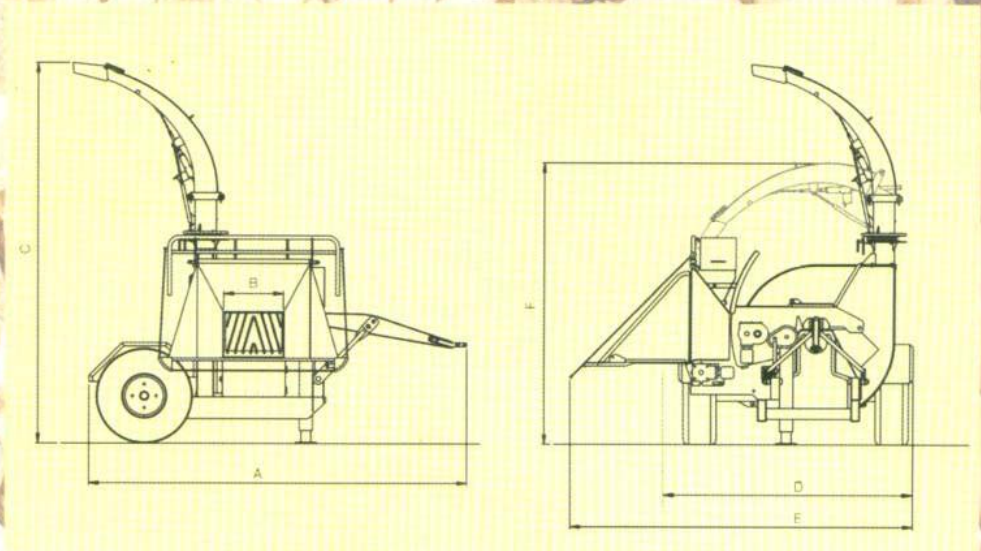

In order to guarantee a save operation while hand-charging, the machines are equipped with a solid switch bar on top of the in-feed table. A steel rope, guided around the front edges of the in-feed table, is connected to the switch bar and makes it possible to stop the in-feed of the machine from all sides in the case of an emergency.



# Heizohack<sup>®</sup>

## HM 8-400 K

The powerful model  
for a professional  
startup

### Heizospan

max. trunk diameter  
40 cm = approx. 16 inch

Remote controlled function like the rotation, lifting and lowering of the ejector, lifting and lowering of the in-feed table, infinitely variable in-feed speed, electronic controlled number of revolutions are standard equipments.





	A	B	C	D	E	F	kg
HM 8-400 K	4482	708	4638	2464	3067	3420	5500

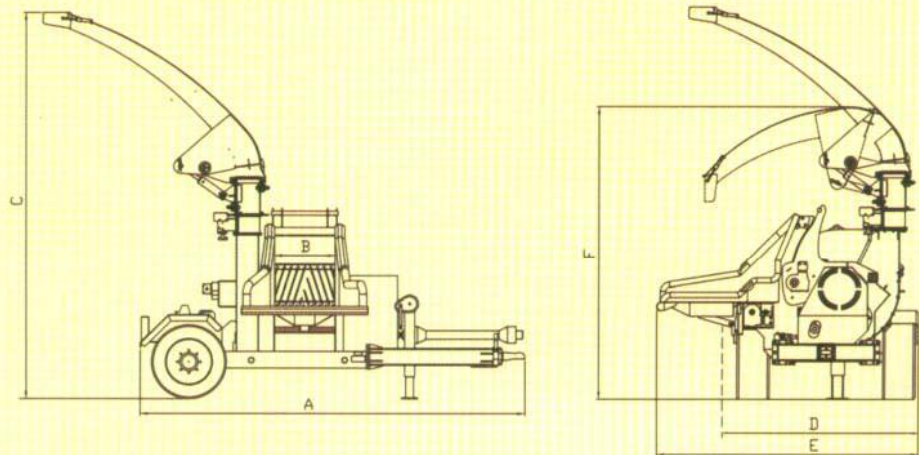

A countershaft with 10 belts allows different transmission ratios in order to transfer various shaft revolutions.



The development of this machine type made it possible to produce the wood chips by an entrepreneur. These powerful machines are built for crane-feeding only!

max. trunk diameter 50 cm =  
approx. 20 inch

This medium sized crane – fed chipper is – like all „K“ chipper – serially equipped with wear blades and a belt transmission gear. Similar to the big brother HM 14-800 K it is equipped with an electric driven hydraulic oil cooler.



	A	B	C	D	E	F	kg
HM 10-500 K	4482	708	4638	2464	3067	3420	5500

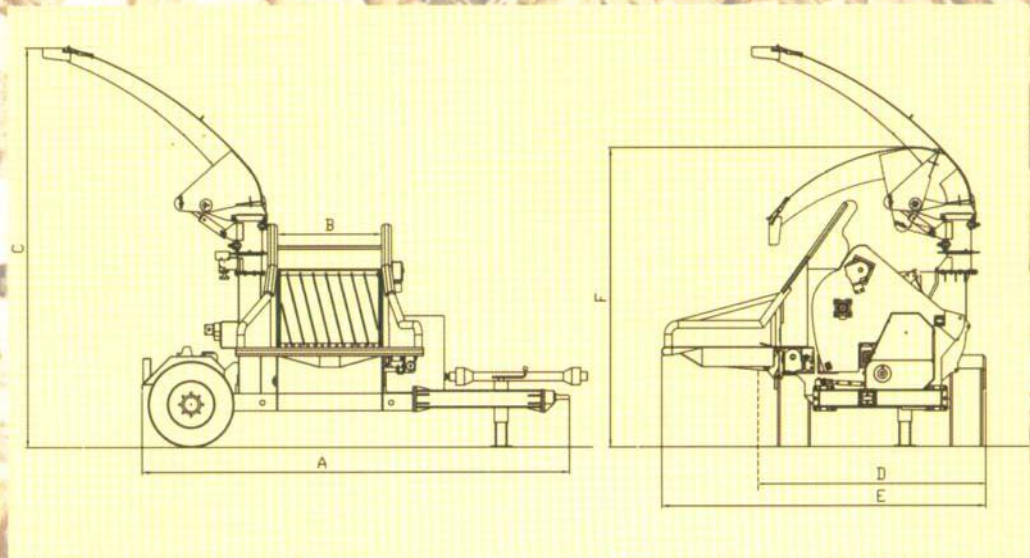

max. trunk diameter 80 cm = approx. 32 inch



The hydraulic-driven functions like lifting and lowering the in-feed table, erection and rotation of the ejector are served by the tractor's own hydraulic system, and allow to do these movements when the chipper is in a stand-still.



An especially feature of the crane-fed machine is the in-feed roller with a diameter of 80 cm and a wide open in-feed table.



	A	B	C	D	E	F	kg
HM 14-800 K	5120	1215	4638	2656	3776	3480	8500

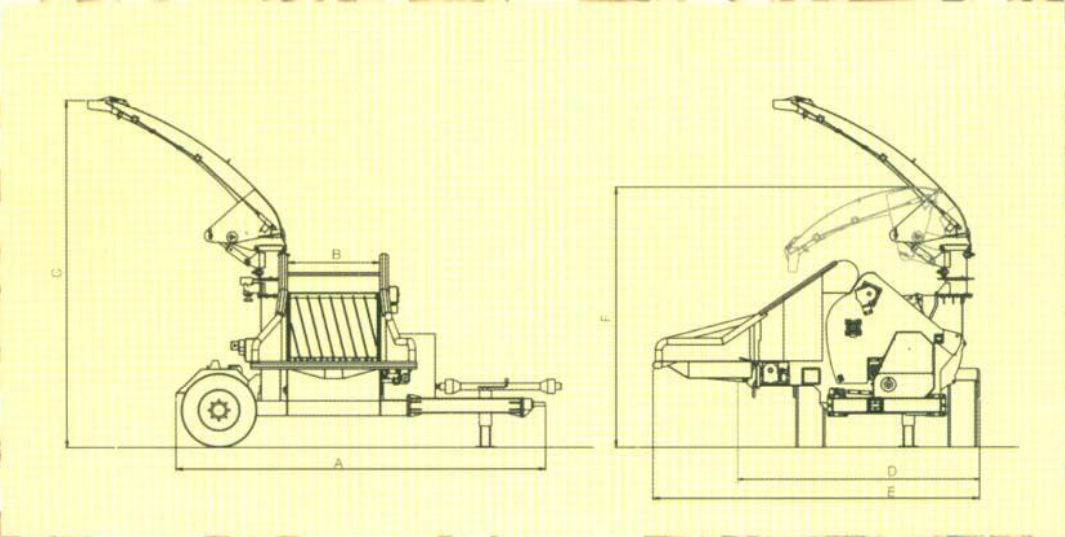

Furthermore there is a possibility to insert an adapter-bracket in the chipping knife clamp to replace small wear blades in a very short time by loosening the central screw.



max. trunk diameter 80 cm = approx. 32 inch



The tandem chassis allows the mounting of a crane on this most powerful wood chipper.

## HM 14-800 KL

# Heizohack®

Built on an all wheel driven Mercedes Actros with 320 hp the HM 14-800 K reaches the place of destination in short time. The chipper is powered by the Mercedes driving motor via an auxiliary drive of the gearbox.



How to find us ... Highway ← Heilbronn - Nürnberg →



Heizomat®

Heizohack®

Heizotrans®

Heizoschneck®

Heizospan®

Heizobaum®

Heizogreif®

Heizoschneid®

Heizohand®

Heizokraft®

**Heizomat®** produces bio-mass heating systems in the range from 15 kW up to 850 KW.

Please contact us. We plan and manufacture your heating system.

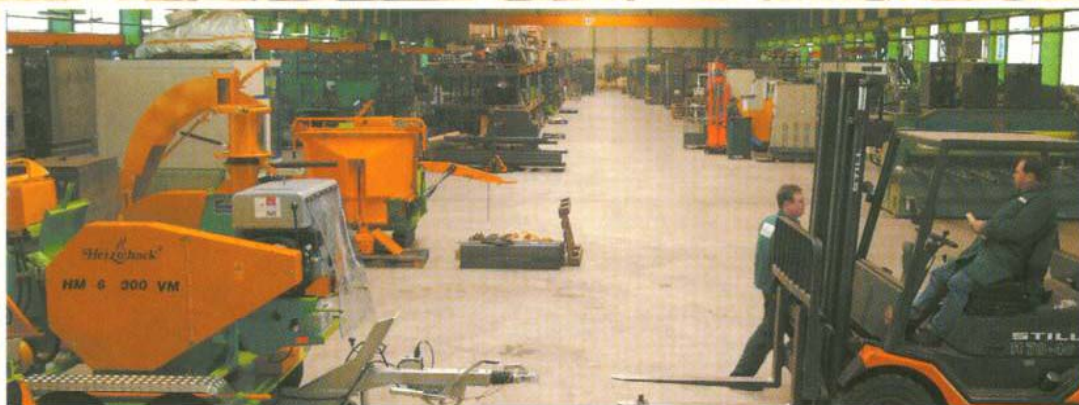

Our partner

# Heizomat®

Heizomat GmbH  
 Maicha 21, 91710 Gunzenhausen  
 Tel. 098 36/97 97-0, Fax 098 36/97 97-97  
[www.heizomat.de](http://www.heizomat.de), [info@heizomat.de](mailto:info@heizomat.de)